

Rotary actuator fail-safe for adjusting dampers in technical building installations

- Air damper size up to approx. 2 m²
- Torque motor 10 Nm
- Nominal voltage AC 230 V
- Control Open/close
- with 2 integrated auxiliary switches

Technical data

Electrical data	Nominal voltage	AC 230 V	
	Nominal voltage frequency	50/60 Hz	
	Nominal voltage range	AC 198...264 V	
	Power consumption in operation	6 W	
	Power consumption in rest position	2.5 W	
	Power consumption for wire sizing	9.5 VA	
	Auxiliary switch	2 x SPDT, 1 x 10% / 1 x 11...90%	
	Switching capacity auxiliary switch	1 mA...3 A (0.5 A inductive), AC 250 V	
	Connection supply / control	Cable 1 m, 2 x 0.75 mm ²	
	Connection auxiliary switch	Cable 1 m, 6 x 0.75 mm ²	
	Parallel operation	Yes (note the performance data)	
	Functional data	Torque motor	10 Nm
		Torque fail-safe	10 Nm
Direction of motion motor		selectable by mounting L/R	
Direction of motion fail-safe		selectable by mounting L/R	
Manual override		by means of hand crank and locking switch	
Angle of rotation		Max. 95°	
Angle of rotation note		adjustable starting at 33% in 2.5% steps (with mechanical end stop)	
Running time motor		75 s / 90°	
Running time fail-safe		<20 s / 90°	
Running time fail-safe note		@ -20...50°C / <60 s @ -30°C	
Sound power level, motor		45 dB(A)	
Mechanical interface		Universal shaft clamp 10...25.4 mm	
Safety		Position indication	Mechanical
	Service life	Min. 60'000 fail-safe positions	
	Protection class IEC/EN	II reinforced insulation	
	Protection class UL	II reinforced insulation	
	Protection class auxiliary switch IEC/EN	II reinforced insulation	
	Degree of protection IEC/EN	IP54	
	Degree of protection NEMA/UL	NEMA 2	
	Enclosure	UL Enclosure Type 2	
	EMC	CE according to 2014/30/EU	
	Low voltage directive	CE according to 2014/35/EU	
	Certification IEC/EN	IEC/EN 60730-1 and IEC/EN 60730-2-14	
	Certification UL	cULus according to UL60730-1A, UL60730-2-14 and CAN/CSA E60730-1:02	
	Certification UL note	The UL marking on the actuator depends on the production site, the device is UL-compliant in any case	
Mode of operation	Type 1.AA.B		
Rated impulse voltage supply / control	4 kV		
Rated impulse voltage auxiliary switch	2.5 kV		
Control pollution degree	3		
Ambient temperature	-30...50°C		
Storage temperature	-40...80°C		
Ambient humidity	Max. 95% r.H., non-condensing		

Technical data

Safety	Servicing	maintenance-free
Weight	Weight	2.2 kg

Safety notes



- The device must not be used outside the specified field of application, especially not in aircraft or in any other airborne means of transport.
- Outdoor application: only possible in case that no (sea) water, snow, ice, insolation or aggressive gases interfere directly with the actuator and that is ensured that the ambient conditions remain at any time within the thresholds according to the data sheet.
- Caution: Power supply voltage!
- Only authorised specialists may carry out installation. All applicable legal or institutional installation regulations must be complied during installation.
- The device may only be opened at the manufacturer's site. It does not contain any parts that can be replaced or repaired by the user.
- Cables must not be removed from the device.
- To calculate the torque required, the specifications supplied by the damper manufacturers concerning the cross-section, the design, the installation site and the ventilation conditions must be observed.
- The two switches integrated in the actuator are to be operated either on power supply voltage or at safety extra-low voltage. The combination power supply voltage/safety extra-low voltage is not permitted.
- The device contains electrical and electronic components and must not be disposed of as household refuse. All locally valid regulations and requirements must be observed.

Product features

Mode of operation	The actuator moves the damper to the operating position at the same time as tensioning the return spring. The damper is turned back to the fail-safe position by spring force when the supply voltage is interrupted.
Simple direct mounting	Simple direct mounting on the damper shaft with a universal shaft clamp, supplied with an anti-rotation device to prevent the actuator from rotating.
Manual override	By using the hand crank the damper can be actuated manually and engaged with the locking switch at any position. Unlocking is carried out manually or automatically by applying the operating voltage.
Adjustable angle of rotation	Adjustable angle of rotation with mechanical end stops.
High functional reliability	The actuator is overload protected, requires no limit switches and automatically stops when the end stop is reached.
Flexible signalization	The actuator has one auxiliary switch with a fixed setting and one adjustable auxiliary switch. They permit a 10% or 11...90% angle of rotation to be signaled.

Accessories

	Description	Type
Electrical accessories	Auxiliary switch 2 x SPDT	S2A-F
	Feedback potentiometer 200 Ω	P200A-F
	Feedback potentiometer 1 kΩ	P1000A-F
	Description	Type
Mechanical accessories	Shaft extension 240 mm Ø20 mm for damper shaft Ø 8...22.7 mm	AV8-25
	End stop indicator	IND-AFB
	Shaft clamp reversible, for central mounting, for damper shafts Ø12.7 / 19.0 / 25.4 mm	K7-2
	Ball joint suitable for damper crank arm KH8 / KH10	KG10A
	Ball joint suitable for damper crank arm KH8	KG8

Accessories

Description	Type
Damper crank arm Slot width 8.2 mm, clamping range Ø10...18 mm	KH8
Actuator arm, for 3/4" shafts, clamping range Ø10...22 mm, Slot width 8.2 mm	KH-AFB
Form fit insert 10x10 mm, Multipack 20 pcs.	ZF10-NSA-F
Form fit insert 12x12 mm, Multipack 20 pcs.	ZF12-NSA-F
Form fit insert 15x15 mm, Multipack 20 pcs.	ZF15-NSA-F
Form fit insert 16x16 mm, Multipack 20 pcs.	ZF16-NSA-F
Mounting kit for linkage operation for flat and side installation	ZG-AFB
Base plate extension	Z-SF
Anti-rotation mechanism 230 mm, Multipack 20 pcs.	Z-ARS230L
Hand crank 63 mm	ZKN2-B

Electrical installation



Notes

- Caution: Power supply voltage!
- Parallel connection of other actuators possible. Observe the performance data.

Wiring diagrams

AC 230 V, open/close

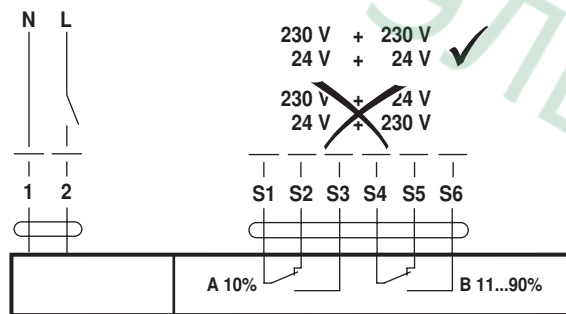

Cable colours:

- 1 = blue
- 2 = brown
- S1 = violet
- S2 = red
- S3 = white
- S4 = orange
- S5 = pink
- S6 = grey

Operating controls and indicators

Auxiliary switch settings

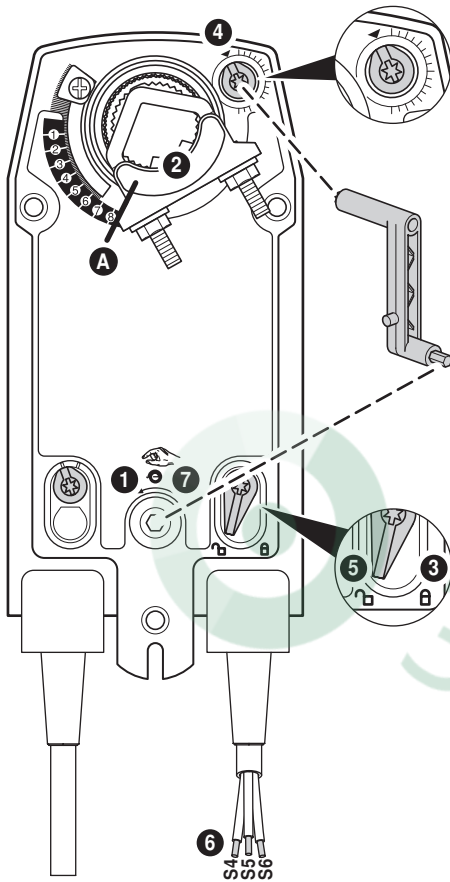

Note: Perform settings on the actuator only in deenergised state.

- 1 Manual override**
Turn the hand crank until the desired switching position is set.
- 2 Spindle clamp**
Edge line **A** displays the desired switching position of the actuator on the scale.
- 3 Fasten the locking device**
Turn the locking switch to the „Locked padlock“ symbol.
- 4 Auxiliary switch**
Turn rotary knob until the notch points to the arrow symbol.
- 5 Unlock the locking device**
Turn the locking switch to the „Unlocked padlock“ symbol or unlock with the hand crank.
- 6 Cable**
Connect continuity tester to S4 + S5 or to S4 + S6.
- 7 Manual override**
Turn the hand crank until the desired switching position is set and check whether the continuity tester shows the switching point.

Dimensions [mm]

Spindle length

		Min. 85
		Min. 15

Clamping range

	10...22	10	14...25.4
	19...25.4	12...18	

Dimensional drawings

